

CROWN OPTO S1



ITEM DESCRIPTION

In front of you – technical information of the updated Crown OPTO S1 module. Crown OPTO S1 was a really good option for illuminating middle-range depth letters and light boxes, but now it is even better. We have equipped S1 with a better LED, resulting in increased life time to L70 50 000 h, hence granting 5 years 24/7 warranty. Crown OPTO S1 – a great option for middle-range depth projects when economical, although quality solution is needed.

APPLICATION

- Channel letters signs and light boxes
- Recommended depth 50 – 120 mm

FEATURES & BENEFITS

- Compact design
- Efficiency up to 107 lm/W
- IP67 protection class
- White, red, green and blue colours are available
- 5 year warranty

GENERAL SPECIFICATIONS

SUPPLY VOLTAGE	12 VDC
POWER	0.75 W
RECOMMENDED DEPTH	From 50 to 120 mm
CC DISTANCE	200 mm
BINNING	3 SDCM
OPERATING TEMPERATURE	-30 °C ~ +50 °C
STORAGE TEMPERATURE	+5 °C ~ +70 °C
STORAGE CONDITIONS	Relative humidity <60%
LIFETIME	L70 50,000 h
IP CLASS	IP 67
WARRANTY	5 years (24/7)*

*Warranty is applied only and if storage, mounting and maintenance conditions, stated in the installation guide, are followed.

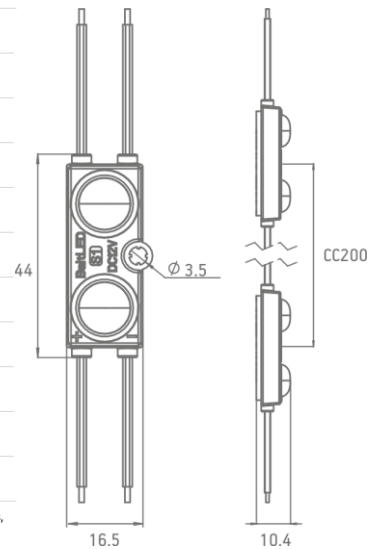

* Dimensions are in mm

LIGHT DISTRIBUTION GRAPH

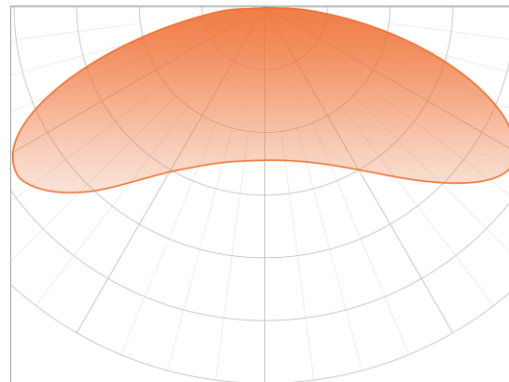

Beam angle: 160°

ORDERING INFORMATION

SKU	POWER, W	LUMEN OUTPUT, LM	COLOUR TEMP.	STATUS
BMP-S1-02UH160CW651	0.75	80	6600 K	IN STOCK
BMP-S1-02UH160CW652	0.75	80	6500 K	IN STOCK
BMP-S1-02UH160NW401	0.75	78	4000 K	IN STOCK
BMP-S1-02UH160WW301	0.75	78	3000 K	IN STOCK
BMP-S1-02UH160RC	0.75	30	red	IN STOCK
BMP-S1-02UH160GC	0.75	50	green	IN STOCK
BMP-S1-02UH160BC	0.75	13	blue	IN STOCK

* Pre-order products will be available only with MOQ from 3000 EUR, lead time 3 – 8 weeks. For precise lead time, contact your Customer Service manager.

CHAIN	BAG	BOX
50 pcs (net weight: 0.401 kg)	100 pcs (net weight: 0.820 kg)	1000 pcs (net weight 8.700 kg)